

# LEVEL FOOT

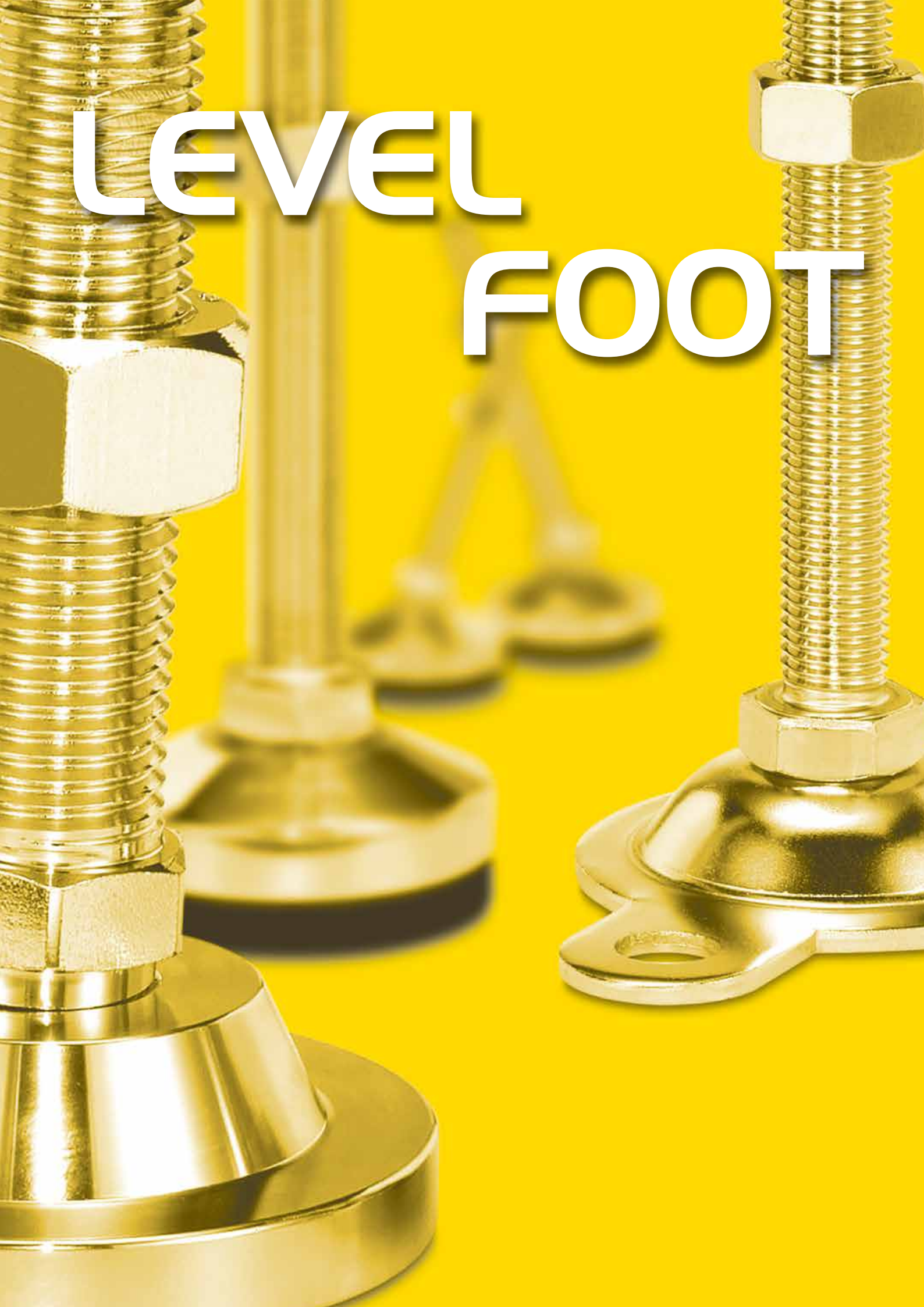

# 기능 및 특성 Function Feature

높낮이 조정기능 · 방진기능 · 흔들림 방지기능 등의 특성을 가진 제품들로 경량용에서 고하중용 조절좌(M6~M52)까지 다양한 규격이 있습니다. 볼트 기울기는 3~5° 입니다.

This product has the function of the high-low, the dust-proof and the rock-proof, and various form from light weight to high pressure levelling foot.

# 주의사항 An Important Matter

장비의 높낮이 조정이 끝난후 반드시 고정용 너트를 고정하여야 흔들림 · 풀림방지 및 하중을 견딜 수 있음.

It just needs to fix the nut after being finished adjusting the high-low for preventing the rock and the loose, and for fearing the pressure.

# 허용하중 Recommended Load

허용하중은 경사면 또는 평탄한 바닥에 기계장비가 서 있는 경우의 하중 한도를 표기하고 있습니다. Levelling Foot는 일반적으로 4개를 기본적으로 장착하지만 한 쪽 부분에 하중이 집중 될 수 있으므로 하중에 따른 모델 선정이 매우 중요하며, 본 카탈로그의 허용하중은 2EA의 Levelling Foot에 집중될 경우의 하중한도를 표기한 것입니다.

The load ratings detailed on this catalogue is for recommended load in levelling foot for based on flat & slope floor. Generally accepted four levelling foot for using, but the load stress that has to be applied 2 levelling foot, It's important to select the levelling foot that will do your job. Therefore, Please care has been taken by recommended load and conditions. It's important to select the casters that will do our job.

# 품질관리 Quality Control

전조로링한 볼트로 → 도금 → 조립 → 포장까지 나사산을 관리하므로 전동공구 또는 에어공구로 손쉽게 장착할 수 있어 작업이 편리합니다. (As the bolt rolled by cylindrical thread rolling controls the screws, it let the working comfortable because of being easily installed by the electric tool and air tool.)



전조로링 (CYLINDRICAL  
THREAD ROLLING)



도금 (PLATING)



조립 (ASSEMBLY)



포장 (PACKING)

# 취부방법 Attachments



※ 단가표는 나사부길이(S)로 표기되어 있습니다.

## 장착 및 취부 Installation and Attachment

### 장착방법 Installation

- 하기 표와 같이 LEVEL FOOT의 크기에 따라 상대물의 두께를 비례하게 적용하여 주십시오.

Please select the LEVEL FOOT in accordance with the thickness of the machine plate as following table.

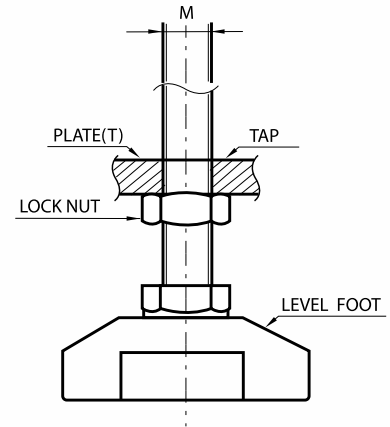

### Level Foot Attachment

LEVEL FOOT	SIZE (m)	M6 ×1.0	M8 ×1.25	M10 ×1.5	M12 ×1.75	M16 ×2.0	M20 ×2.5	M24 ×3.0	M30 ×3.5	M42 ×4.5	Tr42 ×6	Tr52 ×7	Tr60 ×7
MACHINE PLATE THICK (T)		5T (OVER)	6T (OVER)	8T (OVER)	10T (OVER)	13T (OVER)	16T (OVER)	20T (OVER)	25T (OVER)	35T (OVER)	50T (OVER)	60T (OVER)	70T (OVER)

## 배치방법 Application Process of Level Foot

### 배치방법 The Manoeuvrability of Appliances & Machines

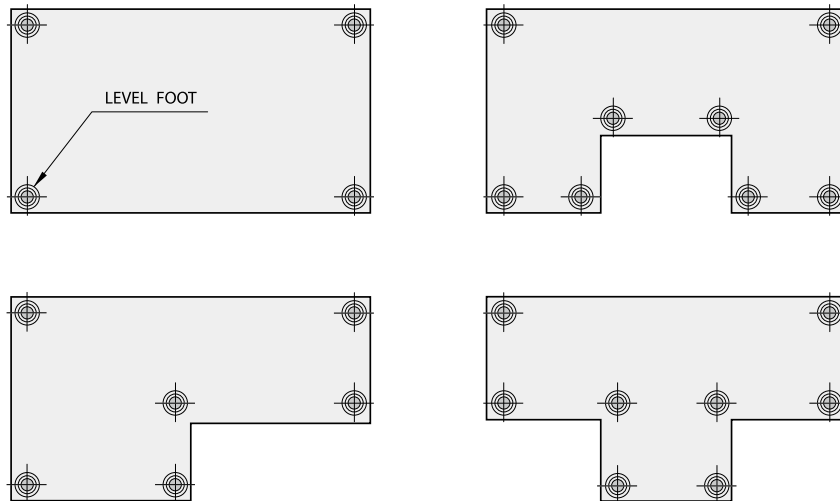

### 장착 후 유의사항 Notice After Attachment

- LEVEL FOOT는 적용장비의 높낮이 조절이 끝나면 하부 고정용 너트를 꼭 고정시켜야 풀림 방지 및 안전 하중을 견디어 줍니다.

LEVEL FOOT should fasten a bolt with a sub-fixed nut after regulate the high and low. Only if it is that way to prevent the loosen products and safety load.

# 각산볼트

중/고하중용  
(MEDIUM & HIGH DUTY PURPOSE)  
STEEL

BLG & ABLG & MFG

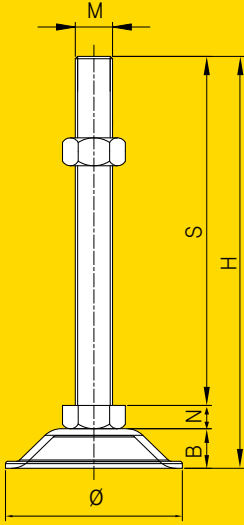

## ※각산볼트 조절좌의 특징

- 적은 토크로 높낮이 조절 용이
- 일반 볼트보다 약 50% 이상의 허용 하중 증가  
- 자체 하중테스트 완료(성적서 발급 가능)
- TR볼트(가공) 대비 가격이 저렴

## PADG-A & PADG-B

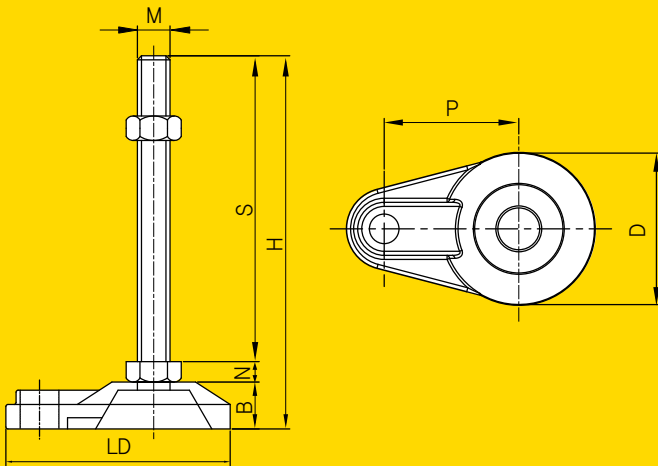

## ※용도

- 반도체장비, LCD장비, 자동화 설비, 전용기

중/고하중용  
(MEDIUM & HIGH DUTY PURPOSE)  
STEEL

# 각산볼트

## BLG & ABLG & MFG

MODEL	DIMENSIONS(m/m)								MATERIALS		표면처리 (FINSH)	허용하중 (4EA/kg)	
	Ø	M	S	H	N	B	LD	P	BOLT&NUT	하부			
BLG NBLG	76	M20x4山	100	130	12	17				SM10C	3t (SPHC)	BLG 아연백색 (Zn)	1500
			150	180									
			200	230									
			250	280									
	95		100	135		22							
			150	185									
			200	235									
			250	285									
ABLG NABLG	76	M20x4山	100	130	12	17	112.8	56.6	SM10C	3t (SPHC)	ABLG 아연백색 (Zn)	1500	
			150	180									
			200	230									
			250	280									
	95		100	135		22	131	65					
			150	185									
			200	235									
			250	285									
MFG	64	M20x4山	100	132	13	19			SM10C	SM45C	MFG 니켈도금 (Ni)	4500	
			150	182									
			200	232									
			250	282									
	78		100	136		23							
			150	186									
			200	236									
			250	286									

## PADG-A & PADG-B

MODEL	DIMENSIONS(m/m)								MATERIALS		표면처리 (FINSH)	허용하중 (4EA/kg)
	Ø	M	S	H	N	B	LD	P	BOLT&NUT	하부		
PADG-A	75	M20x4山	100	137	13	24	122	66	SM10C	단조 (Forged Steel)	아연백색 (Zn)	4500
			150	187								
			200	237								
			250	287								
	84		100	141		28	141	78				
			150	191								
			200	241								
			250	291								
PADG-B	80	M20x4山	100	138	13	25		SM10C	단조 (Forged Steel)	아연백색 (Zn)	4500	
			150	188								
			200	238								
			250	288								

※ RB, RL, NS, FABL, MFN, MFU, NHNR 등 모든 TYPE 주문제작 가능

※표면처리 무전해니켈 by order

# BL & NBL

경/중하중용(LIGHT & MEDIUM DUTY PURPOSE)  
STEEL & STAINLESS

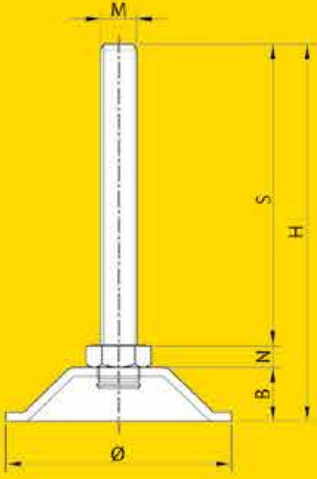

# RB & NRB

경/중하중 미끄럼방지 방진용  
(LIGHT & MEDIUM DUTY CUSHIONING, ANTI-SLIP)  
STEEL & STAINLESS

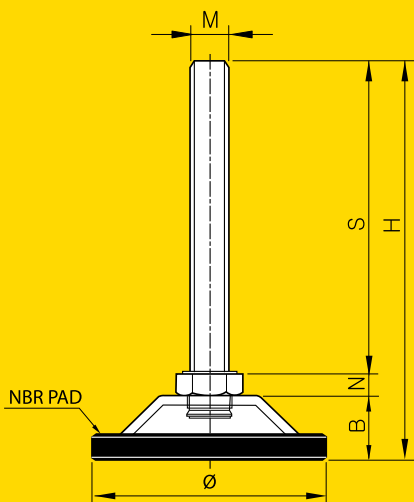

경/중하중용(LIGHT & MEDIUM DUTY PURPOSE)  
STEEL & STAINLESS

# BL & NBL

MODEL	DIMENSIONS(m/m)						MATERIALS		표면처리 (FINSH)	허용하중 (4EA/kg)				
	Ø	M	S	H	N	B	BOLT&NUT	하부						
BL NBL (STEEL)  SBL PSBL (SUS)	36	M6x1.0	40	55	6	9	SM10C	2t(SPHC) 2t(SUS304)	BL 아연백색(Zn)  NBL 니켈도금(Ni)  SBL 일반(Natural)  PSBL 포리싱(PL)	100				
			80	95						200				
		M8x1.25	40	55						7	15	2.6t (SPHC)	300	
			80	95									500	
			100	115										
			150	165										
	50	M10x1.5	60	82	8	15		SUS304		3t (SPHC)  3t (SUS304)	800			
			100	122										
			125	147										
			150	172										
			200	222										
			50	73								10	17	4.5t (SPHC)  4.0t (SUS304)
		80	103											
		90	113											
		100	123											
		130	153											
		150	173											
		200	223											
		250	273											
		63	M12x1.75	300								323	13	22
	50			75										
	80			105										
	100			125										
	130			155										
	150			175										
	M16x2.0		180	205	16	25		4.5t (SPHC) 4t (SUS304)		2200				
			200	225										
			250	275										
			300	325										
	76	M16x2.0	50	77	16	25		6t (SPHC) 6t (SUS304)		2500				
			80	107										
			100	127										
			130	157										
			150	177										
			180	207										
			200	227										
			250	277										
		300	327											
		M20x2.5	80	110							16	25	6t (SPHC) 6t (SUS304)	2500
			100	130										
130			160											
150			180											
180			210											
200			230											
95		M20x2.5	250	280			16		25		6t (SPHC) 6t (SUS304)	2500		
			300	330										
			80	115										
	100		135											
	130		165											
	150		185											
	M24x3.0	180	215	16	25	6t (SPHC) 6t (SUS304)		2500						
		200	235											
		250	285											
		300	335											
105	M24x3.0	100	138	16	25	6t (SPHC) 6t (SUS304)	2500							
		130	168											
		150	188											
		200	238											
		250	288											
		300	338											
105	M24x3.0	100	141	16	25	6t (SPHC) 6t (SUS304)	2500							
		130	171											
		150	191											
		200	241											
		250	291											
		300	341											

※ 기타 특수사양은 주문제작함(PARTICULAR CASE IS MADE-TO-ORDER)

※표면처리 무전해니켈 by order

높낮이 조절좌

LF-7

# RB & NRB

경/중하중 미끄럼방지 방진용  
(LIGHT & MEDIUM DUTY CUSHIONING, ANTI-SLIP)  
STEEL & STAINLESS



MODEL	DIMENSIONS(m/m)						MATERIALS		표면처리 (FINSH)	허용하중 (4EA/kg)					
	Ø	M	S	H	N	B	BOLT&NUT	하부							
RB NRB (STEEL)  SRB PSRB (SUS)	40	M6x1.0	40	59	6	13	SM10C  SUS304	2t(SPHC) 2t(SUS304)	RB 아연백색(Zn)  NRB 니켈도금(Ni)  SRB 일반(Natural)  PSRB 포리싱(PL)	100					
			80	99						200					
		M8x1.25	40	59						7	20	2.6t (SPHC)	500		
			80	99											
			100	119											
			150	169											
	55	M10x1.5	60	87	8	21		3t (SPHC) 2.5t (SUS304)		600					
			100	127											
			125	152											
			150	177											
		M12x1.75	50	78							10	23	3t (SUS304)	800	
			80	108											
			90	118											
			100	128											
	68	M12x1.75	130	158	10	29		4.5t (SPHC) 4.0t (SUS304)		1500					
			150	178											
			200	228											
			250	278											
			300	328											
			M16x2.0	50							79	13	29	4.5t (SPHC) 4.0t (SUS304)	1500
				80							109				
		90		119											
		100		129											
		130		159											
		150		179											
		200		229											
		81	M16x2.0	50							83	13	29	4.5t (SPHC) 4.0t (SUS304)	1500
				80							113				
	100			133											
	130			163											
	M20x2.5		150	183	13	29		4.5t (SPHC) 4.0t (SUS304)		1500					
			180	213											
			200	233											
			250	283											
	103	M16x2.0	300	333	13	29		4.5t (SPHC) 4.0t (SUS304)		1500					
			80	116											
100			136												
130			166												
150			186												
M20x2.5		180	216	13			29		4.5t (SPHC) 4.0t (SUS304)		1500				
		200	236												
		250	286												
		300	336												
		80	122									13	29	4.5t (SPHC) 4.0t (SUS304)	1500
100	142														
130	172														
150	192														
180	222														
103	M20x2.5	200	242	13	29	4.5t (SPHC) 4.0t (SUS304)	1500								
		250	292												
		300	342												
		80	122					13	29	4.5t (SPHC) 4.0t (SUS304)	1500				
		100	142												
130	172														
150	192														
180	222														

※ 기타 특수사양은 주문제작함(PARTICULAR CASE IS MADE-TO-ORDER)

※표면처리 무전해니켈 by order



경/중하중 미끄럼방지 방진용  
(LIGHT & MEDIUM DUTY CUSHIONING, ANTI-SLIP)  
STEEL & STAINLESS

# RL & NRL

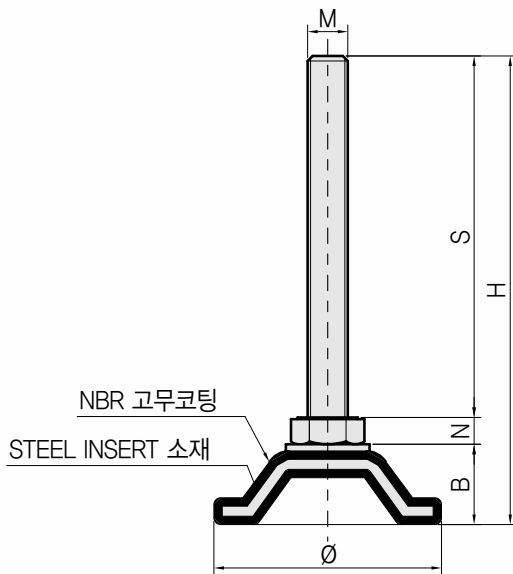

MODEL	DIMENSIONS(m/m)						MATERIALS		표면처리 (FINSH)	허용하중 (4EA/kg)			
	Ø	M	S	H	N	B	BOLT&NUT	하부+고무코팅					
RL NRL (STEEL)  SRL (SUS)	40	M6x1.0	40	62	6	16	SM10C  SUS304	2t(SPHC) 2t(SUS304)	RL 아연백색 (Zn)	100			
			80	102						200			
		M8x1.25	40	62						7	24	2.6t(SPHC) 2.5t(SUS304)	300
			80	102									
			100	122									
			150	172									
	55	M10x1.5	60	91	8	25		3t (SPHC)  3t (SUS304)		NRL 니켈도금 (Ni)	600		
			100	131									
			125	156									
			150	181									
			200	231									
			68	M12x1.75								50	83
	80	113											
	90	123											
	100	133											
	130	163											
	150	183											
	82	M16x2.0	50	90	13	1000							
			80	120									
			100	140									
			130	170									
			150	190									
			180	220									
		M20x2.5	200	240									
250			290										
300			340										
80			123										
100			143										
130			173										
150	193												
180	223												
200	243												
250	293												
300	343												

※ 기타 특수사양은 주문제작함(PARTICULAR CASE IS MADE-TO-ORDER)

※표면처리 무전해니켈 by order

# ABL&NABL

경/중하중 앵카용  
(LIGHT & MEDIUM DUTY PURPOSE ANCHOR STYLE)  
STEEL & STAINLESS

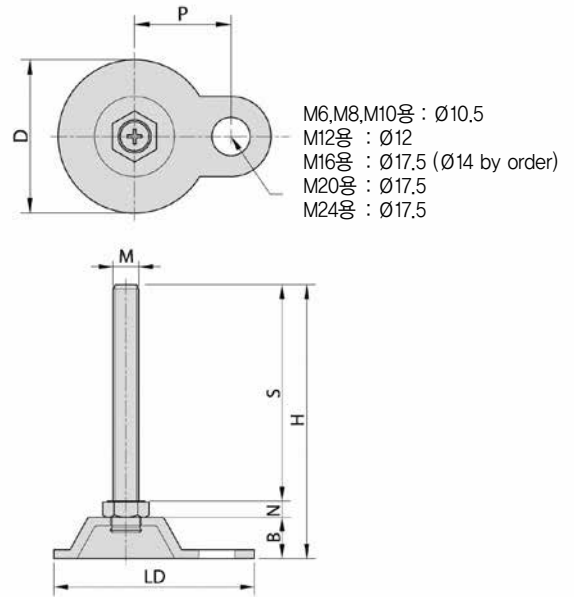

MODEL	DIMENSIONS(m/m)								MATERIALS		표면처리 (FINSH)	허용하중 (4EA/kg)						
	D	M	S	H	N	B	LD	P	BOLT&NUT	하부								
ABL NABL (STEEL)	42	M6x1.0	40	58	6	12	57.5	26.5	26.5	2.6t (SPHC) 2.5t (SUS304)	ABL 아연백색 (Zn)	100						
			80	98								200						
			40	58								300						
		M8x1.25	80	98								7	100	118	600			
			150	168									150	169				
			200	219									200	219				
		M10x1.5	60	79	8								100	119		56.6		
			125	144									125	144				
			150	169									150	169				
		M12x1.75	200	219								10	50	73			1000	
			80	103									80	103				
			90	113									90	113				
	100		123	100	123													
	130		153	130	153													
	150		173	150	173													
	76	M16x2.0	200	223	13	17	112.8	56.6	SM10C  SUS304	3t (SPHC)  3t (SUS304)	NABL 니켈도금 (Ni)	800						
			250	273									250	273				
			300	323									300	323				
			80	110									80	110				
			100	130									100	130				
			130	160									130	160				
		M20x2.5	150	180	13					22	131	65	4.5t (SPHC) 4.0t (SUS304)	SABL 일반 (Natural)	PSABL 포리싱 (PL)	1500		
			180	210													180	210
			200	230													200	230
250			280	250													280	
300			330	300													330	
100			138	100													138	
M24x3.0	130	168	16	25	146	74	4.5t (SPHC) 4t (SUS304)	2200										
	150	188							150				188					
	200	238							200				238					
	250	288							250				288					
	300	338							300				338					
	100	141							100				141					
105	M24x3.0	130	171				16	25	146	74	6t (SPHC) 6t (SUS304)	2500						
		150	191										150	191				
		200	241										200	241				
		250	291										250	291				
		300	341										300	341				

※ 기타 특수사양은 주문제작함(PARTICULAR CASE IS MADE-TO-ORDER)

※표면처리 무전해니켈 by order

경/중하중 앵카용  
(LIGHT & MEDIUM DUTY PURPOSE ANCHOR STYLE)  
STEEL & STAINLESS

# ABLP & NABLP

**NEW**

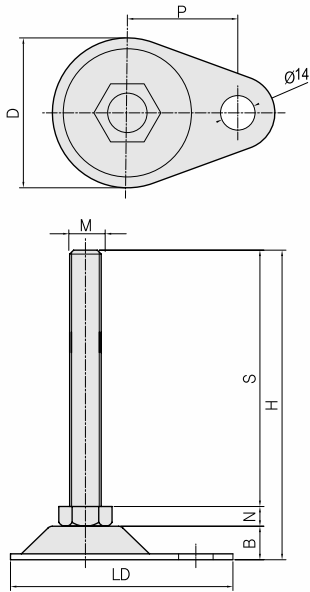

MODEL	DIMENSIONS(m/m)								MATERIALS		표면처리 (FINSH)	허용하중 (4EA/kg)			
	D	M	S	H	N	B	LD	P	BOLT&NUT	하부					
ABLP NABLP (STEEL)	55	M12x1.75	50	71	8	13	85	45	SM10C	3t (SPHC)	ABLP 아연백색 (Zn)	500			
			80	101											
			90	111											
			100	121											
			130	151											
			150	171											
			200	221											
			250	271											
		300	321												
		M16x2.0	50	73	10										
			80	103											
			100	123											
	130		153												
	150		173												
	180		203												
	75	M12x1.75	50	75	8	17	115	65				SUS304	3t (SUS304)	NABLP 니켈도금 (Ni)	500
			80	105											
			90	115											
			100	125											
			130	155											
			150	175											
		M16x2.0	50	77	10										
			80	107											
			100	127											
130			157												
150			177												
180			207												
M20x2.5	80	110	13	1000											
	100	130													
	130	160													
	150	180													
	180	210													
	200	230													
SABLP PSABLP (SUS)	M12x1.75	130	155		8	17	115	65	SUS304	3t (SUS304)	SABLP 일반 (Natural)	500			
		150	175												
		200	225												
		250	275												
		300	325												
		M16x2.0	50										77	10	1000
80	107														
100	127														
130	157														
150	177														
180	207														
M20x2.5	80	110	13	1000											
	100	130													
	130	160													
	150	180													
	180	210													
	200	230													
PSABLP (SUS)	M12x1.75	250	275		8	17	115	65	SUS304	3t (SUS304)	PSABLP 포리싱 (PL)	500			
		300	325												
		M16x2.0	50										77	10	1000
			80										107		
			100										127		
			130										157		
150	177														
180	207														
M20x2.5	80	110	13	1000											
	100	130													
	130	160													
	150	180													
	180	210													
	200	230													

※ 기타 특수사양은 주문제작함(PARTICULAR CASE IS MADE-TO-ORDER)

※표면처리 무전해니켈 by order

# ARB&NARB

경/중하중 방진 앵카용  
(LIGHT & MEDIUM DUTY CUSHIONING ANCHOR STYLE)  
STEEL & STAINLESS

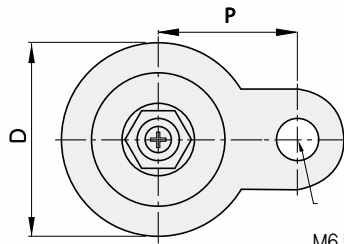

M6,M8,M10용 : Ø10.5  
M12용 : Ø12  
M16용 : Ø17.5  
M20용 : Ø17.5  
M24용 : Ø17.5

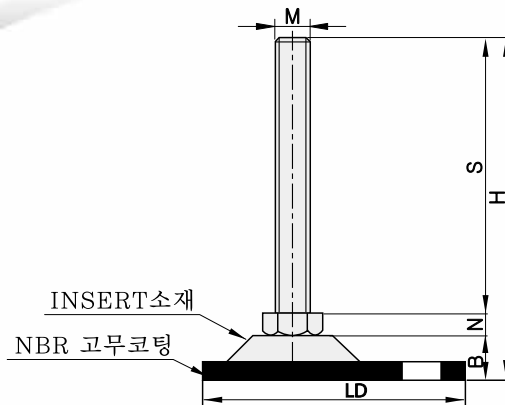

경/중하중 방진 앵카용  
(LIGHT & MEDIUM DUTY CUSHIONING ANCHOR STYLE)  
STEEL & STAINLESS

# ARB & NARB

MODEL	DIMENSIONS(m/m)								MATERIALS		표면처리 (FINSH)	허용하중 (4EA/kg)
	D	M	S	H	N	B	LD	P	BOLT&NUT	하부+고무코팅		
ARB NARB (STEEL)  SARB PSARB (SUS)	46	M6x1.0	40	62	6	16	62.5	26.5	SM10C	하부+고무코팅	2.6 (SPHC) 2.5t (SUS304)	100
			80	102								
		M8x1.25	40	62								
			80	102								
			100	122								
			150	172								
		M10x1.5	60	83	7							
			100	123								
			125	148								
			150	173								
			200	223								
			250	273								
	68	M12x1.75	50	78	8	20	89.3	39	SM10C	하부+고무코팅	2.6 (SPHC) 2.5t (SUS304)	200
			80	108								
			90	118								
			100	128								
			130	158								
			150	178								
			200	228								
			250	278								
	81	M16x2.0	50	83	10	23	118	56	SM10C	하부+고무코팅	3t (SPHC) 3t (SUS304)	800
			80	113								
			100	133								
			130	163								
			150	183								
			180	213								
		M20x2.5	200	233	13							
			250	283								
			300	333								
			80	116								
			100	136								
			130	166								
103	M20x2.5	150	186	13	28	138	67	SM10C	하부+고무코팅	4.5t (SPHC) 4.0t (SUS304)	1500	
		180	216									
		200	236									
		250	286									
		300	336									
		80	121									16
	100	141										
	130	171										
	150	191										
	180	221										
	200	241										
	M24x3.0	250	291	16								
300		341										
100		144										
130		174										
150		194										
200		244										
250	294											
300	344											

※ 기타 특수사양은 주문제작함(PARTICULAR CASE IS MADE-TO-ORDER)

※표면처리 무전해니켈 by order

# FABL & NFABL

경/중하중 2홀 앙카용  
(LIGHT & MEDIUM DUTY PURPOSE TWO HOLE ANCHOR STYLE)  
STEEL & STAINLESS



7090

90140

MODEL	DIMENSIONS(m/m)						MATERIALS		표면처리 (FINISH)	허용하중 (4EA/kg)
	D	M	S	H	N	B	BOLT&NUT	하부		
FABL NFABL (STEEL)  SFABL PSFABL (SUS)	7090	M12x1.75	50	71	8	13	SM10C  SUS304		FABL 아연백색 (Zn)  NFABL 니켈도금 (Ni)  SFABL 일반 (Natural)  PSFABL 포리싱 (PL)	500
			80	101						
			90	111						
			100	121						
			130	151						
			150	171						
			200	221						
			250	271						
		300	321							
		M16x2.0	50	73	10					
			80	103						
			100	123						
	130		153							
	150		173							
	180		203							
	M20x2.5	80	106	13						
		100	126							
		130	156							
		150	176							
		180	206							
		200	226							
	90140	M20x2.5	250	276	13	20				
			300	326						
			80	113						16
100			133							
130			163							
150			183							
180		213								
200		233								
250		283								
300		333								
M24x3.0		100	136	16						
		130	166							
	150	186								
	200	236								
	250	286								
	300	336								

※ 기타 특수사양은 주문제작함(PARTICULAR CASE IS MADE-TO-ORDER)

※표면처리 무전해니켈 by order

경하중 방진용(LIGHT DUTY CUSHIONING TYPE)  
STEEL & STAINLESS

NS

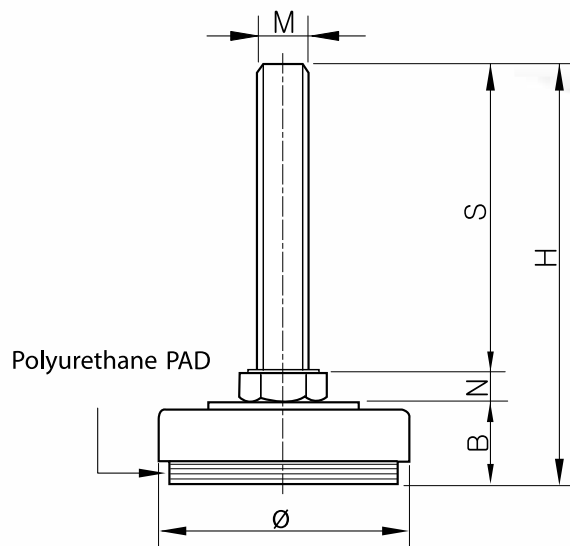



경하중 방진용(LIGHT DUTY CUSHIONING TYPE)  
STEEL & STAINLESS



MODEL	DIMENSIONS(m/m)						MATERIALS		표면처리 (FINSH)	하용하중 (4EA/kg)
	Ø	M	S	H	N	B	BOLT&NUT	하부		
NS (STEEL)  SNS (SUS)	30	M6x1.0	40	61	6	15	SM10C  SUS304	2t (SPHC)  2t (SUS304)	NS 니켈도금(Ni)  SNS 포리싱(PL)	100
			80	101						200
			40	61						100
		M8x1.25	80	101						200
			100	121						100
			150	171						200
	40 (38)	M6x1.0	40	63	17	17				100
			80	103						200
			40	63						100
		M8x1.25	80	103						200
			100	123						300
			150	173						500
	48	M10x1.5	60	84.5	7	17.5				300
			100	124.5						500
			125	149.5						700
			150	174.5						800
			200	224.5						1000
		M12x1.75	50	75.5	8					900
			80	105.5						1000
			90	115.5						1200
			100	125.5						1500
			130	155.5						2000
			150	175.5						2500
			200	225.5						3000
		M16x2.0	50	77.5	10					3500
			80	107.5						4000
			100	127.5						4500
			130	157.5						5000
			150	177.5						5500
			180	207.5						6000
	61	M12x1.75	50	75.5	8	17.5				6000
			80	105.5						7000
			90	115.5						8000
			100	125.5						9000
			130	155.5						10000
		M16x2.0	150	175.5	10					11000
			200	225.5						12000
			250	275.5						13000
			300	325.5						14000
			80	110.5						13
100	130.5	16000								
130	160.5	17000								
150	180.5	18000								
180	210.5	19000								
72	M16x2.0	200	230.5	10	20	20000				
		250	280.5			21000				
		300	330.5			22000				
		50	80			13	23000			
		80	110				24000			
		100	130				25000			
		130	160				26000			
	150	180	27000							
	180	210	28000							
	200	230	29000							
	M20x2.5	250	280	13		30000				
		300	330			31000				
		80	113			32000				
		100	133			33000				
130		163	34000							
150		183	35000							
180		213	36000							
200	233	37000								
250	283	38000								
300	333	39000								

※ 기타 특수사양은 주문제작함(PARTICULAR CASE IS MADE-TO-ORDER)

※표면처리 무전해니켈 by order



중/고하중용  
(MEDIUM & HEAVY PURPOSE)  
STEEL & STAINLESS

MF

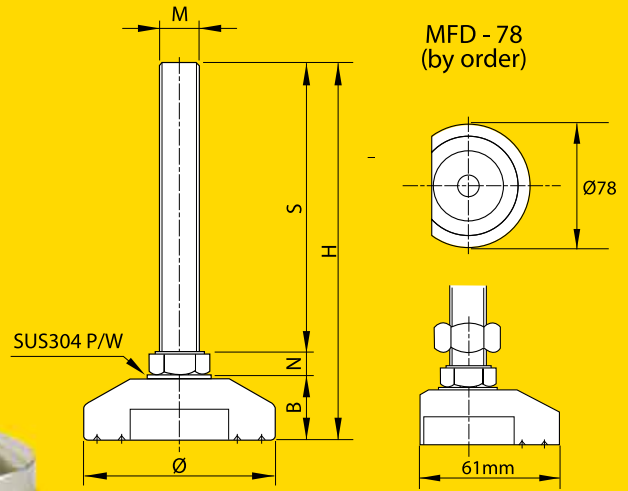

중/고하중 방진용  
(MEDIUM & HEAVY PURPOSE CUSHIONING TYPE)  
STEEL & STAINLESS

MFR

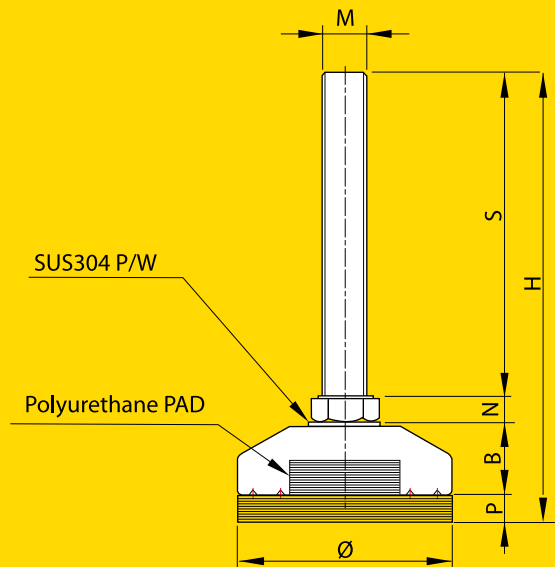



중/고하중용  
(MEDIUM & HEAVY PURPOSE)  
STEEL & STAINLESS



MODEL	DIMENSIONS(m/m)						MATERIALS		표면처리 (FINSH)	허용하중 (4EA/kg)
	Ø	M	S	H	N	B	BOLT&NUT	하부		
53	M12x1.75	50	74	8	16					1000
		80	104							
		90	114							
		100	124							
		130	154							
		150	174							
		200	224							
		250	274							
		300	324							
		50	76							
59	M12x1.75	80	106	10	18					2000
		90	116							
		100	126							
		130	156							
		150	176							
		200	226							
		250	276							
		300	326							
59 64	M16x2.0	50	79	13	19		SM10C SUS304	SM45C SUS304	MF 니켈도금(Ni)  SMF 산처리 (Natural)	3000
		80	109							
		100	129							
		130	159							
		150	179							
		180	209							
		200	229							
		250	279							
		300	329							
		50	86							
78	M16x2.0	80	116	16	26					4000
		100	136							
		130	166							
		150	186							
		180	216							
		200	236							
		250	286							
		300	336							
64	M20x2.5	80	112	19	19					5000
		100	132							
		130	162							
		150	182							
		180	212							
		200	232							
		250	282							
		300	332							
		80	119							
		78	M20x2.5							
130	169									
150	189									
180	219									
200	239									
250	289									
300	339									
100	142									
78	M24x3.0	130	172	16	26					4000
		150	192							
		200	242							
		250	292							
		300	342							
98	M24x3.0	100	146	19	30					5000
		130	176							
		150	196							
		200	246							
		250	296							
78	M30x3.5	300	346	22	30		SM45C SUS304			6000
		100	145							
		150	195							
		200	245							
		250	295							
98	M30x3.5	300	345	19	30					5000
		100	149							
		150	199							
		200	249							
		250	299							
98	M42x4.5	300	349	22	30					6000
		150	202							
		200	252							
		250	302							
		300	352							
128 148	M42x4.5	150	203	22	31					6000
		200	253							
		250	303							
		300	353							
		300	353							

※ 기타 특수사양은 주문제작함(PARTICULAR CASE IS MADE-TO-ORDER)

※표면처리 무전해니켈 by order



중/고하중용 방진용  
(MEDIUM & HEAVY PURPOSE CUSHIONING TYPE)  
STEEL & STAINLESS

# MFR

MODEL	DIMENSIONS(m/m)							MATERIALS		표면처리 (FINSH)	허용하중 (4EA/kg)
	∅	M	S	H	N	B	P	BOLT&NUT	하부		
MFR (STEEL)  SMFR (SUS)	53	M12x1.75	50	80	8	16	6	SM10C  SUS304	SM45C  SUS304	MFR 니켈도금(Ni)  SMFR 산처리 (Natural)	1000
			80	110							
			90	120							
			100	130							
			130	160							
			150	180							
			200	230							
			250	280							
	300	330									
	59	M12x1.75	50	84	8	18	8				
			80	114							
			90	124							
			100	134							
			130	164							
			150	184							
			200	234							
			250	284							
	300	334									
	59 64	M16x2.0	50	87	10	19	8				
			80	117							
			100	137							
			130	167							
			150	187							
			180	217							
			200	237							
			250	287							
	300	337									
	78	M16x2.0	50	96	10	26	10				
			80	126							
			100	146							
			130	176							
			150	196							
			180	226							
			200	246							
			250	296							
	300	346									
	64	M20x2.5	80	120	13	19	8				
			100	140							
			130	170							
			150	190							
			180	220							
			200	240							
250			290								
300			340								
78	M20x2.5	80	129	13	26	8					
		100	149								
		130	179								
		150	199								
		180	229								
		200	249								
		250	299								
		300	349								
78	M24x3.0	100	152	16	26	8					
		130	182								
		150	202								
		200	252								
		250	302								
98	M24x3.0	100	156	16	30	10					
		130	186								
		150	206								
		200	256								
		250	306								
78	M30x3.5	100	155	19	26	8					
		150	205								
		200	255								
		250	305								
		300	355								
98	M30x3.5	100	159	19	30	8					
		150	209								
		200	259								
		250	309								
		300	359								
98	M42x4.5	150	212	22	30	8					
		200	262								
		250	312								
		300	362								
128 148	M42x4.5	150	218	22	31	15					
		200	268								
		250	318								
		300	368								

※ 기타 특수사양은 주문제작함(PARTICULAR CASE IS MADE-TO-ORDER)

※표면처리 무전해니켈 by order

# MFB

## 고하중용 베어링형 (HEAVY DUTY BEARING TYPE) STEEL & STAINLESS

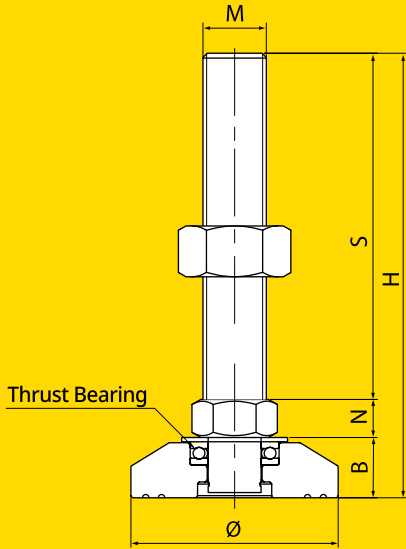

• 베어링 삽입으로 고하중시  
높이 조절이 용이

MODEL	DIMENSIONS(m/m)						MATERIALS		표면처리 (FINISH)	허용하중 (4EA/kg)				
	Ø	M	S	H	N	B	BOLT&NUT	하부						
MFB (STEEL)	78	M24x3.0	100	142.5	16	26.5	SM45C SUS304	SM45C SUS304	MFB 니켈도금(Ni)	4000				
			130	172.5										
			150	192.5										
			200	242.5										
			250	292.5										
			300	342.5										
	98	M24x3.0	100	146.5	19	30.5								
			130	176.5										
			150	196.5										
			200	246.5										
			250	296.5										
			300	346.5										
	78	M30x3.5	100	145.5	19	26.5					SM45C SUS304	SM45C SUS304	SMFB 산처리 (Natural)	5000
			150	195.5										
200			245.5											
250			295.5											
300			345.5											
300			345.5											
98	M30x3.5	100	149.5	22	31.5									
		150	199.5											
		200	249.5											
		250	299.5											
		300	349.5											
		300	349.5											
98	M42x4.5	150	203.5	22	31.5	SM45C SUS304	SM45C SUS304	MFB 니켈도금(Ni)	6000					
		200	253.5											
		250	303.5											
		300	353.5											
		300	353.5											
		300	353.5											
128 148	M42x4.5	150	203.5	22	31.5									
		200	253.5											
		250	303.5											
		300	353.5											

※표면처리 무전해니켈 by order

중/고하중용  
(MEDIUM & HEAVY PURPOSE)  
STEEL & STAINLESS

# MFT

(보급형)

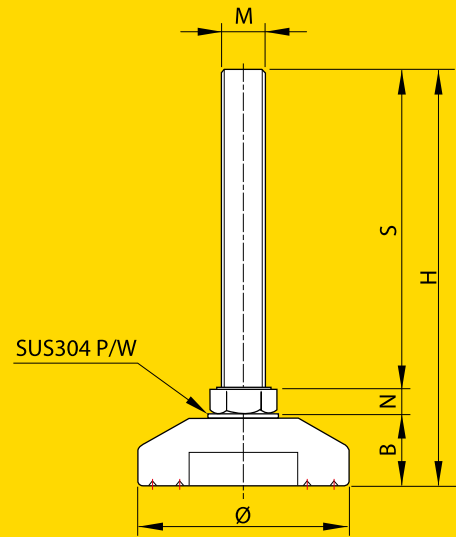

중/고하중용 방진용  
(MEDIUM & HEAVY PURPOSE CUSHIONING TYPE)  
STEEL & STAINLESS

# MFTR

(보급형)

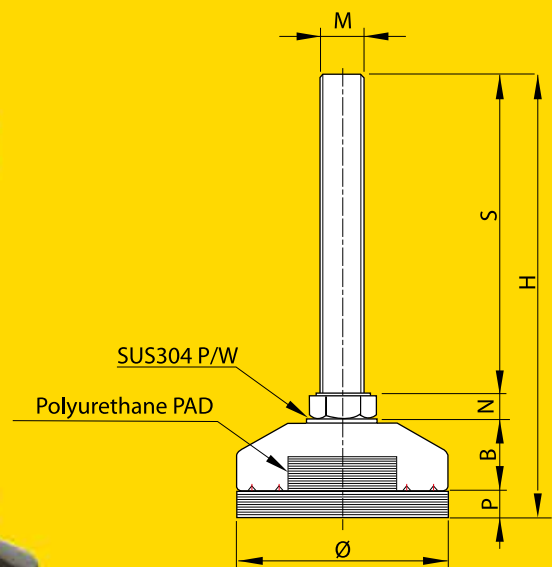



## (보급형)

※MF형에 비해 하부PAD(브치수)가 얇습니다.

MODEL	DIMENSIONS(m/m)						MATERIALS		표면처리 (FINSH)	허용하중 (4EA/kg)	
	∅	M	S	H	N	B	BOLT&NUT	하부			
MFT (STEEL) SMFT (SUS)	38	M10x1.5	60	83	7	16	SM10C SUS304	SM45C SUS304	MFT 니켈도금(Ni)  SMFT 일반(Natural)	1000	
			100	123							
			125	148							
			150	173							
			200	223							
	49	M12x1.75	50	74	8						
			80	104							
			90	120							
			100	124							
			130	154							
			150	174							
			200	224							
	78	M16x2.0	50	79	10						19
			80	109							
			100	129							
			130	159							
			150	179							
			180	209							
		200	229								
		250	279								
		300	329								
		88	M20x2.5	80		112				13	
	100			132							
	130			162							
	150			182							
	180			212							
	200			232							
	250			282							
	300			332							
	98	M24x3.0	100	135	16	21					
			130	165							
			150	185							
200			235								
250			285								
300		335									
M24x3.0		100	137	19							
		130	167								
		150	187								
		200	237								
	250	287									
M30x3.5	100	140	19								
	150	190									
	200	240									
	250	290									
	300	340									

※ 기타 특수사양은 주문제작함(PARTICULAR CASE IS MADE-TO-ORDER)

※표면처리 무전해니켈 by order



중/고하중용 방진용  
(MEDIUM & HEAVY PURPOSE CUSHIONING TYPE)  
STEEL & STAINLESS

# MFTR

(보급형)

※MFTR형에 비해 하부PAD(브치수)가 얇습니다.

MODEL	DIMENSIONS(m/m)							MATERIALS		표면처리 (FINSH)	허용하중 (4EA/kg)					
	Ø	M	S	H	N	B	P	BOLT&NUT	하부							
MFTR (STEEL) SMFTR (SUS)	38	M10x1.5	60	89	7							MFTR 니켈도금(Ni)  SMFTR 일반(Natural)	1000			
			100	129												
			125	154												
			150	179												
			200	229												
	49	M12x1.75	50	80	8	16	6								2000	
			80	110												
			90	120												
			100	130												
			130	160												
			150	180												
			200	230												
			250	280												
	300	330														
	78	M16x2.0	50	89	10				SM10C	SM45C						3000
			80	119												
			100	139												
			130	169												
			150	189												
			180	219												
			200	239												
			250	289												
		300	339													
		M20x2.5	80	122	13	19			SUS304	SUS304					4000	
			100	142												
			130	172												
			150	192												
			180	222												
			200	242												
	250		292													
300	342															
88	M24x3.0	100	145	16								5000				
		130	175													
		150	195													
		200	245													
		250	295													
		300	345													
98	M24x3.0	100	147	16									4000			
		130	177													
		150	197													
		200	247													
		250	297													
	300	347														
	M30x3.5	100	150	19	21										5000	
		150	200													
		200	250													
		250	300													
300		350														

※ 기타 특수사양은 주문제작함(PARTICULAR CASE IS MADE-TO-ORDER)

※표면처리 무전해니켈 by order

# MFZ & MFA

중/고하중용  
(MEDIUM & HEAVY PURPOSE)  
BOLT : STEEL & STAINLESS  
CUP : Zn & AL

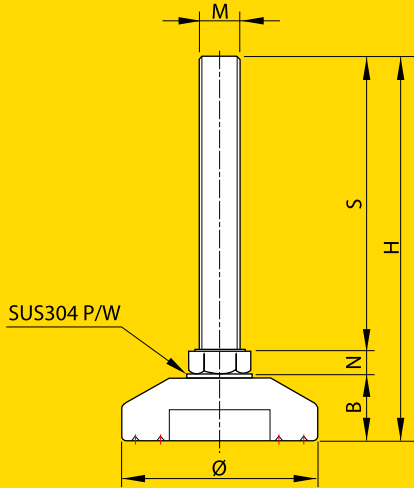

# MFZR & MFAR

중/고하중용 방진용  
(MEDIUM & HEAVY PURPOSE CUSHIONING)  
BOLT : STEEL & STAINLESS  
CUP : Zn & AL

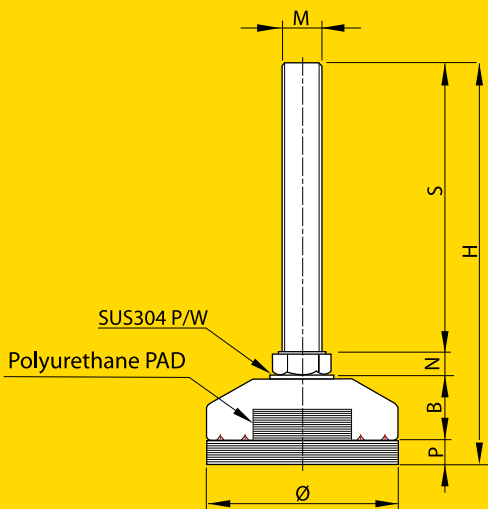



중/고하중용  
(MEDIUM & HEAVY PURPOSE)  
BOLT : STEEL & STAINLESS  
CUP : Zn & AL

# MFZ & MFA

MODEL	DIMENSIONS(m/m)						MATERIALS		표면처리 (FINSH)	허용하중 (4EA/kg)			
	Ø	M	S	H	N	B	BOLT&NUT	하부					
MFZ MFA (BOLT: STEEL)	53	M12x1.75	50	77	8	19	SM10C	아연 (Zn)	MFZ MFA 니켈도금(Ni)	1000			
			80	107									
			90	117									
			100	127									
			130	157									
			150	177									
			200	227									
			250	277									
			300	327									
	64	M12x1.75	50	79	21								
			80	109									
			90	119									
			100	129									
			130	159									
			150	179									
			200	229									
			250	279									
			300	329									
	53	M16x2.0	50	80	20								
			80	110									
			100	130									
			130	160									
			150	180									
			180	210									
			200	230									
	64	M16x2.0	50	82	10	22				SUS304	알루미늄 (AL)	SUS BOLT: 산처리 (Natural)	2000
			80	112									
			100	132									
130			162										
150			182										
180			212										
200			232										
78	M16x2.0	50	86	26									
		80	116										
		100	136										
		130	166										
		150	186										
		180	216										
		200	236										
64	M20x2.5	80	115	13	22								
		100	135										
		130	165										
		150	185										
		180	215										
		200	235										
		250	285										
78	M20x2.5	80	119	26									
		100	139										
		130	169										
		150	189										
		180	219										
		200	239										
		250	289										
300	339												

하부 컵은 아연 또는 알루미늄 재질이며 가공후 니켈도금한 제품으로 부식이 방지되고 스테인레스와 동일한 특성을 지니며 가격이 저렴한 것이 장점입니다.  
The cup in the lower is made from zinc or aluminum casting and nickel-plated after processing itself. So this having the same characteristic to stainless-steel it prevents rust from happening and especially the price is cheap.

※ 기타 특수사양은 주문제작함(PARTICULAR CASE IS MADE-TO-ORDER)

※표면처리 무전해니켈 by order  
높낮이 조절좌 LF-25

# MFZR & MFAR

중/고하중용 방진용  
(MEDIUM & HEAVY PURPOSE  
CUSHIONING TYPE)  
BOLT : STEEL & STAINLESS  
CUP : Zn & AL



MODEL	DIMENSIONS(m/m)							MATERIALS		표면처리 (FINSH)	허용하중 (4EA/kg)
	∅	M	S	H	N	B	P	BOLT&NUT	하부		
MFZR MFAR (BOLT: STEEL)	53	M12x1.75	50	83	8	19	6	SM10C	아연 (Zn)	MFZR MFAR 니켈도금(Ni)	1000
			80	113							
			90	123							
			100	133							
			130	163							
			150	183							
			200	233							
			250	283							
	300	333									
	64	M12x1.75	50	87		21	8				
			80	117							
			90	127							
			100	137							
			130	167							
			150	187							
			200	237							
250			287								
300	337										
53	M16x2.0	50	86	10	20	6					
		80	116								
		100	136								
		130	166								
		150	186								
		180	216								
		200	236								
		250	286								
300	336										
64	M16x2.0	50	90		22	8					
		80	120								
		100	140								
		130	170								
		150	190								
		180	220								
		200	240								
		250	290								
300	340										
78	M16x2.0	50	96	26	10						
		80	126								
		100	146								
		130	176								
		150	196								
		180	226								
		200	246								
		250	296								
300	346										
64	M20x2.5	80	123	13	22	8					
		100	143								
		130	173								
		150	193								
		180	223								
		200	243								
		250	293								
		300	343								
78	M20x2.5	80	129		26	10					
		100	149								
		130	179								
		150	199								
		180	229								
		200	249								
		250	299								
		300	349								

하부 컵은 아연 또는 알루미늄 재질이며 가공후 니켈도금한 제품으로 부식이 방지되고 스테인레스와 동일한 특성을 지니며 가격이 저렴한 것이 장점입니다.  
The cup in the lower is made from zinc or aluminum casting and nickel-plated after processing itself. So this having the same characteristic to stainless-steel it prevents must from happening and especially the price is cheap.

※ 기타 특수사양은 주문제작함(PARTICULAR CASE IS MADE-TO-ORDER)

※표면처리 무전해니켈 by order

중/고하중용  
(MEDIUM & HEAVY PURPOSE)  
STEEL & STAINLESS

# MFN

## Features 특징

- 바닥경사면에 사용



MFN-59컵만 15°

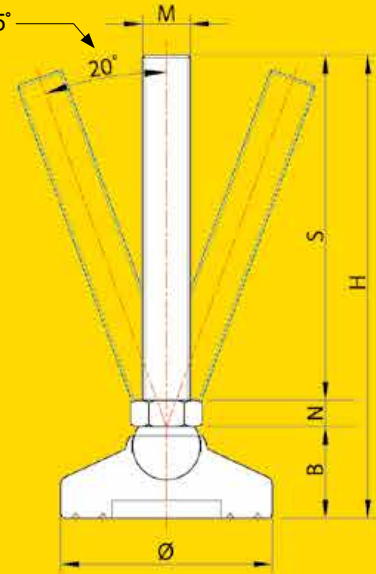

중/고하중용 방진용  
(MEDIUM & HEAVY PURPOSE CUSHIONING TYPE)  
STEEL & STAINLESS

# MFNR

## Features 특징

- 바닥경사면에 사용하며 방진 및 미끄럼 방지용



MFNR-59 컵만 15°

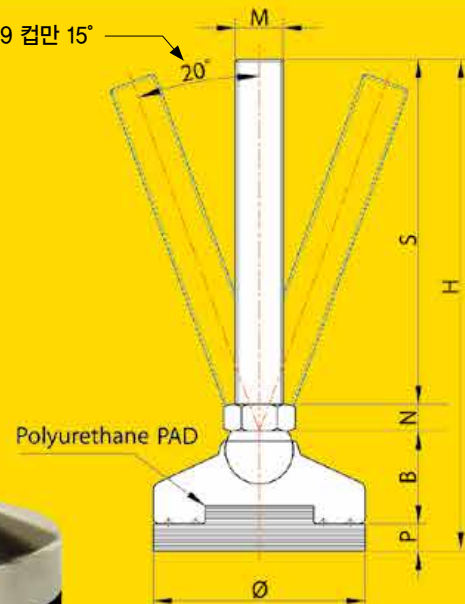



- 각도조절기능이 있어 바닥경사면 사용에 용이

MODEL	DIMENSIONS(m/m)						MATERIALS		표면처리 (FINSH)	허용하중 (4EA/kg)	
	∅	M	S	H	N	B	BOLT&NUT	하부			
MFN (STEEL) SMFN (SUS)	59 (15°)	M12x1.75	80	115	8	27	SM10C SUS304	SM45C SUS304	MFN 니켈도금 (Ni) SMFN 일반 (Natural)	1000	
			90	125							
			100	135							
			130	165							
			150	185							
			200	235							
			250	285							
			300	335							
	59 (15°)	M16x2.0	50	87	10	27					2000
			80	117							
			100	137							
			130	167							
			150	187							
			180	217							
			200	237							
			250	287							
	78 (20°)	M16x2.0	50	89	10	29				2000	
			80	119							
			100	139							
			130	169							
			150	189							
			180	219							
			200	239							
			250	289							
		300	339								
		M20x2.5	100	142	13	29				3000	
			130	172							
			150	192							
			180	222							
			200	242							
			250	292							
			300	342							
98 (20°)	M24x3.0		100	148			16	32	4000		
		130	178								
		150	198								
		200	248								
		250	298								
	M30x3.5	100	151	19	32	5000					
		150	201								
		200	251								
		250	301								
		300	351								
128 148 (20°)	M42x4.5	150	225	30	45	6000					
		200	275								
		250	325								
		300	375								

※ 기타 특수사양은 주문제작함(PARTICULAR CASE IS MADE-TO-ORDER)

※표면처리 무전해니켈 by order



중/고하중용 방진용  
(MEDIUM & HEAVY PURPOSE CUSHIONING TYPE)  
STEEL & STAINLESS

# MFNR

- 각도조절기능이 있어 바닥경사면 사용에 용이

MODEL	DIMENSIONS(m/m)							MATERIALS		표면처리 (FINSH)	허용하중 (4EA/kg)
	Ø	M	S	H	N	B	P	BOLT&NUT	하부		
MFNR (STEEL)  SMFNR (SUS)	59 (15°)	M12x1.75	80	123	8	27	8	SM10C SUS304	SM45C  SUS304	MFNR 니켈도금 (Ni)  SMFNR 일반 (Natural)	1000
			90	133							
			100	143							
			130	173							
			150	193							
			200	243							
			250	293							
			300	343							
	59 (15°)	M16x2.0	50	95	10	27	10				
			80	125							
			100	145							
			130	175							
			150	195							
			180	225							
			200	245							
			250	295							
	300	345									
	78 (20°)	M16x2.0	50	99	10	29	10				
			80	129							
			100	149							
			130	179							
			150	199							
			180	229							
			200	249							
			250	299							
		300	349								
		M20x2.5	100	152	13	29	10				
			130	182							
			150	202							
			180	232							
			200	252							
			250	302							
			300	352							
	98 (20°)		M24x3.0	100							158
		130		188							
		150		208							
200		258									
250		308									
300		358									
M30x3.5		100	161	19	32	10					
		150	211								
		200	261								
		250	311								
	300	361									
128 148 (20°)	M42x4.5	150	240	30	45	15					
		200	290								
		250	340								
		300	390								

※ 기타 특수사양은 주문제작함(PARTICULAR CASE IS MADE-TO-ORDER)

※표면처리 무전해니켈 by order

# MFU 고하중용(ULTRA HEAVY DUTY PURPOSE) STEEL (크롬도금) & STAINLESS

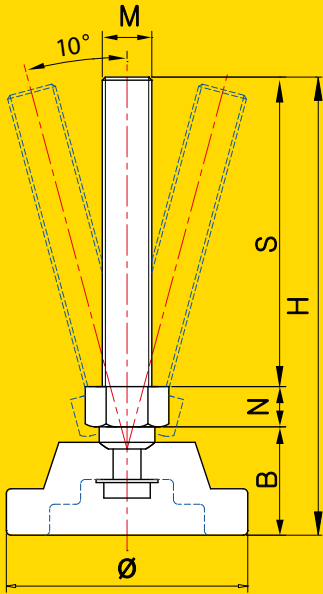

LEVEL FOOT



• 각도조절기능이 있어 바닥경사면 사용에 용이

MODEL	DIMENSIONS(m/m)						MATERIALS		표면처리 (FINSH)	허용하중 (4EA/kg)			
	Ø	M	S	H	N	B	BOLT&NUT	하부					
MFU (STEEL)	78	M16x2.0	100	148	13	35	SM45C	SM45C	MFU 크롬도금 (Cr)	2000			
			150	198									
			200	248									
	98	M20x2.5	100	148	13	35				SUS304	SUS304	SMFU 산처리 (Natural)	3000
			150	198									
			200	248									
SMFU (SUS)	98	M24x3.0	100	155	14	41	SM45C	SM45C	MFU 크롬도금 (Cr)	4000			
			130	185									
			150	205									
	128	M30x3.5	200	255	14	41				SUS304	SUS304	SMFU 산처리 (Natural)	5000
			250	305									
			100	155									
128	M36x4.0	150	215	20	45	SUS304	SUS304	SMFU 산처리 (Natural)	5500				
		200	265										
		250	315										
	148	M42x4.5	150	215	20				45	SUS304	SUS304	SMFU 산처리 (Natural)	6000
			200	265									
			250	315									
148	M52x5.0	150	225	25	50	SUS304	SUS304	SMFU 산처리 (Natural)	8000				
		200	275										
		250	325										

고하중용으로 각도 조절이 되며 반도체 장비 및 시험장비에 적합하도록 설계되어 고하중 정밀한 장비에도 최적의 조건을 유지해 준다.

This production used to the heavy weight pressure and able to adjust any wanted angle, Not only is this designed to be suitable for the equipment for testing and semiconductor, but also this keeps condition most suitable even in the cases on heavy weight and precision instrument.

※ 기타 특수사양은 주문제작함(PARTICULAR CASE IS MADE-TO-ORDER)

※표면처리 무전해니켈 by order

경하중 방진용(LIGHT CUSHIONING TYPE)  
STEEL & STAINLESS

# FR & PL

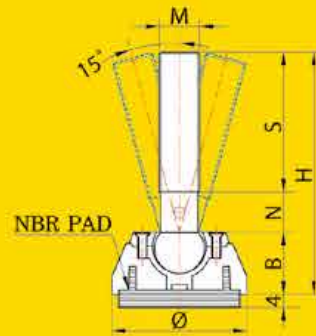

• 각도조절기능이 있어 바닥경사면 사용에 용이

MODEL	DIMENSIONS(m/m)						MATERIALS		표면처리 (FINSH)	허용하중 (4EA/kg)
	Ø	M	S	H	N	B	BOLT&NUT	하부		
FR (ZN&STEEL)	54	M16x2.0	60	104	15	25	SM10C	Zn	크롬도금 (Cr)	1000
			100	144						

※ 기타 특수사양은 주문제작함(PARTICULAR CASE IS MADE-TO-ORDER)

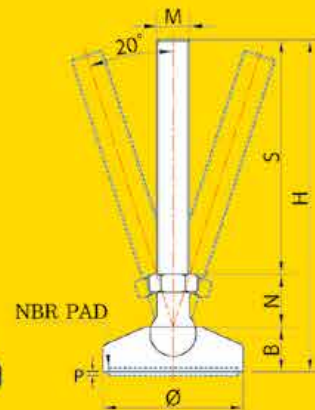

※ 특수 강화플라스틱 사용으로 파손에 강함

PL-90

PL-90 • 각도조절기능이 있어 바닥경사면 사용에 용이

MODEL	DIMENSIONS(m/m)							MATERIALS		표면처리 (FINSH)	허용하중 (4EA/kg)		
	Ø	M	S	H	N	B	P	BOLT&NUT	하부				
PL NPL (STEEL)	40	M6x1.0	40	63	10	13	일체형	SM10C PLASTIC	PLASTIC (사출)	PL 아연백색 (Zn)	100		
			80	103							200		
		M8x1.25	40	63							400		
			80	103							500		
	60	M12x1.75	70	122	26	24	2			PLASTIC (사출)	NPL 니켈도금 (Ni)	400	
			115	167								500	
		M16x2.0	70	122								600	
			115	167								800	
	90	M16x2.0	70	132	26	30	6				PLASTIC (사출)	SPL 일반 (Natural)	600
			115	177									800
		M20x2.5	200	262									600
			200	262									800
SPL (SUS)	40	M6x1.0	40	63	10	13	일체형	SUS304 PLASTIC	PLASTIC (사출)			SPL 일반 (Natural)	100
			80	103									200
		M8x1.25	40	63									400
			80	103									500
	60	M12x1.75	70	122	26	24	2			PLASTIC (사출)		SPL 일반 (Natural)	400
			115	167									500
		M16x2.0	70	122									600
			115	167									800
	90	M16x2.0	70	132	26	30	6				PLASTIC (사출)	SPL 일반 (Natural)	600
			115	177									800
		M20x2.5	200	262									600
			200	262									800

※ 기타 특수사양은 주문제작함(PARTICULAR CASE IS MADE-TO-ORDER)

# NHNR-65 & NHNR-65 (평)

경하중 방진용(LIGHT DUTY CUSHIONING TYPE)  
STEEL & STAINLESS

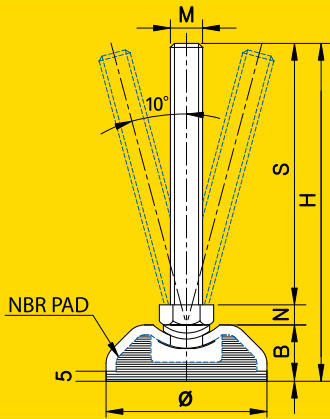

NHNR-65



- 각도조절기능이 있어 바닥경사면 사용에 용이

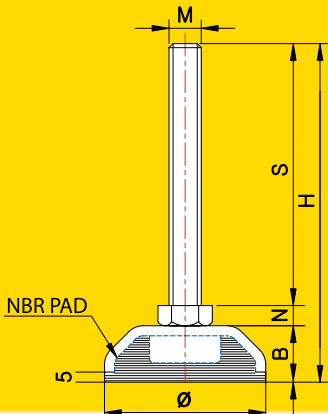

NHNR-65(평)



MODEL	DIMENSIONS(m/m)						MATERIALS		표면처리 (FINISH)	허용하중 (4EA/kg)		
	Ø	M	S	H	N	B	BOLT&NUT	하부(STEEL)				
NHNR (STEEL)	65	M12x1.75	50	86	10	26	SM10C	3t (SPHC)	NHNR 니켈도금 (Ni)	500		
			80	116								
			90	126								
			100	136								
			130	166								
			150	186								
200		236										
SNHNR (SUS)		M16x2.0	50	88	12				SUS304	3t (SUS304)	흑색분체 도장 (Black painting)	800
			80	118								
			100	138								
			130	168								
			150	188								
	180		218									
NHNR(평) (STEEL)	M20x2.5	250	288	15			SNHNR 포리싱(PL)	1000				
		80	121									
		100	141									
		130	171									
		150	191									
		180	221									
SNHNR(평) (SUS)		200	241									
		250	291									

※ 기타 특수사양은 주문제작함(PARTICULAR CASE IS MADE-TO-ORDER)

※표면처리 무전해니켈 by order



중하중 방진용(MEDIUM CUSHIONING TYPE)  
STEEL & STAINLESS

# NHNR-80

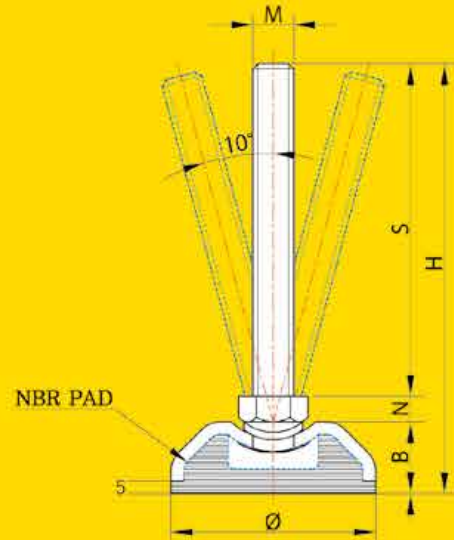

- 각도조정기능이 있어 바닥경사면 사용에 용이

MODEL	DIMENSIONS(m/m)						MATERIALS		표면처리 (FINSH)	허용하중 (4EA/kg)
	Ø	M	S	H	N	B	BOLT&NUT	하부(STEEL)		
NHNR (STEEL) SNHNR (SUS)	80	M12x1.75	50	88	10	28	SM10C SUS304	4t (SPHC) 4t (SUS304)	NHN 니켈도금 (Ni) 흑색분체 도장 (Black painting) SNHN 포리싱(PL)	600
			80	118						
			90	128						
			100	138						
			130	168						
			150	188						
			200	238						
		M16x2.0	50	90	12	28				
			80	120						
			100	140						
			130	170						
			150	190						
			180	220						
		M20x2.5	200	240	15	28				
			250	290						
			80	123						
			100	143						
			130	173						
150	193									
180	223									
200	243									
250	293									

※ 기타 특수사양은 주문제작함(PARTICULAR CASE IS MADE-TO-ORDER)

※표면처리 무전해니켈 by order

# PAD-A

중/고하중 앵카용  
(MEDIUM & HEAVY DUTY PURPOSE ANCHOR STYLE)  
STEEL & (Stainless by Order)

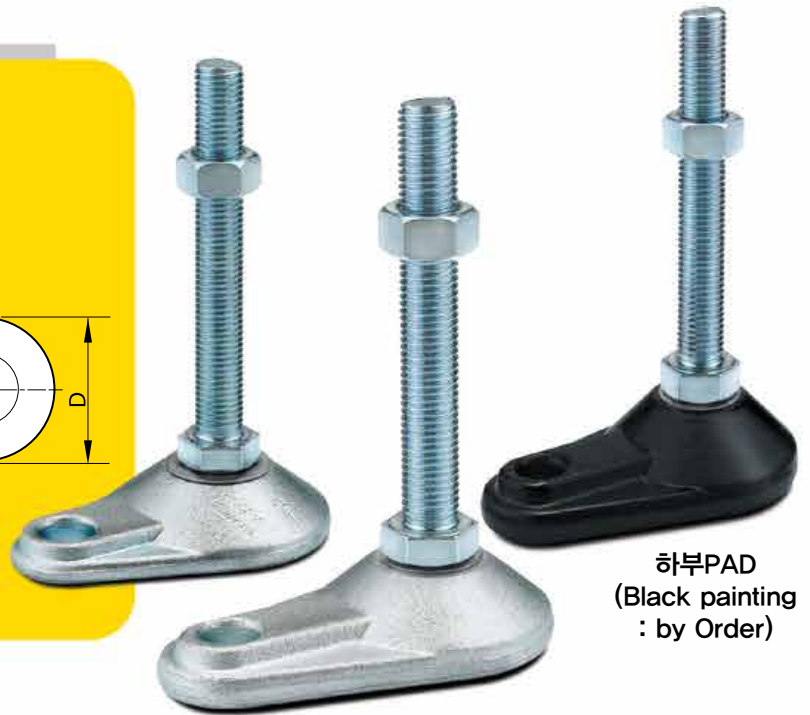
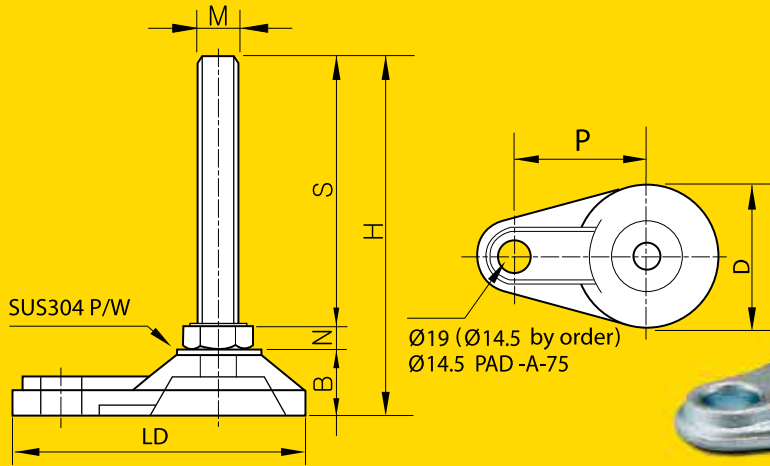

하부PAD  
(Black painting  
: by Order)

# PAD-B

중/고하중용  
(MEDIUM & HEAVY DUTY PURPOSE)  
STEEL & (Stainless by Order)

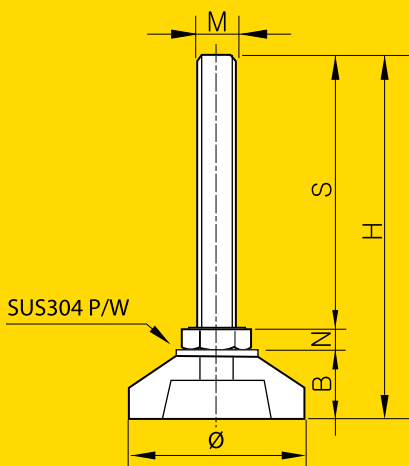

하부PAD  
(Black painting : by Order)

중/고하중 앵카용  
(MEDIUM & HEAVY DUTY PURPOSE ANCHOR STYLE)  
STEEL & (Stainless by Order)

# PAD-A

MODEL	DIMENSIONS(m/m)								MATERIALS		표면처리 (FINSH)	허용하중 (4EA/kg)	
	D	M	S	H	N	B	LD	P	BOLT&NUT	하부			
PAD-A (STEEL)	75	M16x2.0	50	84	10	24	122	66	SM10C	단조 (Forged Steel)	아연백색 (Zn)	2000	
			80	114									
			100	134									
			130	164									
			150	184									
			180	214									
			200	234									
			250	284									
		300	334										
		M20x2.5	80	117	13	24							3000
			100	137									
			130	167									
			150	187									
			180	217									
	200		237										
	84	M16x2.0	50	88	10	28	141	78				2000	
			80	118									
			100	138									
			130	168									
			150	188									
			180	218									
			200	238									
			250	288									
		300	338										
		M20x2.5	80	121	13	28							3000
			100	141									
			130	171									
			150	191									
180			221										
200	241												
100	M24x3.0	100	149	16	33	159	90	4000					
		130	179										
		150	199										
		200	249										
		250	299										
	300	349											
	M30x3.5	100	152	19	33			5000					
		150	202										
		200	252										
		250	302										
300		352											

※ 기타 특수사양은 주문제작함(PARTICULAR CASE IS MADE-TO-ORDER)

※표면처리 무전해니켈 by order

# PAD-B

중/고하중용  
(MEDIUM & HEAVY DUTY PURPOSE)  
STEEL & (Stainless by Order)



MODEL	DIMENSIONS(m/m)						MATERIALS		표면처리 (FINSH)	허용하중 (4EA/kg)
	D	M	S	H	N	B	BOLT&NUT	하부		
PAD-B (STEEL)	60	M12x1.75	50	75	8	17	SM10C	단조 (Forged Steel)	아연백색 (Zn)	1000
			80	105						
			90	115						
			100	125						
			130	155						
			150	175						
			200	225						
			250	275						
			300	325						
	66	M16x2.0	50	80	10	20				2000
			80	110						
			100	130						
			130	160						
			150	180						
			180	210						
			200	230						
			250	280						
			300	330						
	80	M16x2.0	50	85	10	25				2000
			80	115						
			100	135						
			130	165						
			150	185						
			180	215						
			200	235						
			250	285						
			300	335						
		M20x2.5	80	118	13	25				3000
			100	138						
			130	168						
			150	188						
			180	218						
			200	238						
			250	288						
			300	338						
			100	M24x3.0						
130	178									
150	198									
200	248									
250	298									
300	348									
M30x3.5	100	151		19	32	5000				
	150	201								
	200	251								
	250	301								
	300	351								
	120	M30x3.5					100	151	19	32
150			201							
200			251							
250			301							
300			351							
M42x4.5			150	207	24	33	SM45C			
		200	257							
		250	307							
		300	357							

※ 기타 특수사양은 주문제작함(PARTICULAR CASE IS MADE-TO-ORDER)

※표면처리 무전해니켈 by order

STEEL &  
STAINLESS

# ANCHOR BRACKET

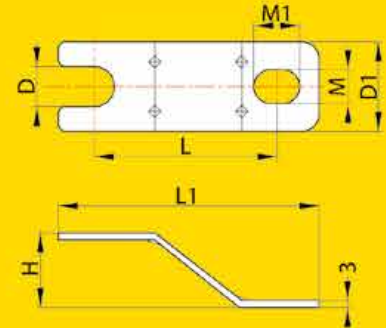

※ 조절좌 높이 안맞을경우 와서 사용

MODEL	DIMENSIONS(m/m)							재질	표면처리 (FINSH)
	D	D1	M	M1	L	L1	H		
ANP-12	12.5	25	10.5	15	80.5	108	28	3.0t (SPHC)	니켈도금 (Ni)
ANP-16	16.5	37	14	19	75.5	108	33		
ANP-20	20.5	37	14	19	75.5	108	36		
SANP-12	12.5	25	10.5	15	80.5	108	28	3.0t (SUS304)	포리싱 (PL)
SANP-16	16.5	37	14	19	75.5	108	33		
SANP-20	20.5	37	14	19	75.5	108	36		

# WORK TABLE FOOT BASE

사출(PLASTIC)

MODEL	DIMENSIONS(m/m)		허용하중 (4EA/kg)
	규격	두께	
FB50 (사각파이프)	50x50	-	3000
FB40 (사각파이프)	40x40	-	2600
FB50C (ㄱ자앵글)	50x50	3t	2400

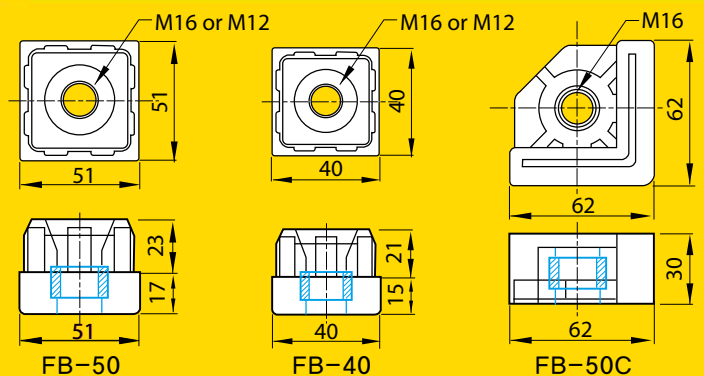

# 콤비 PAD

COMBINATION PAD

재질 : 닥타일 주물(FCD-45)

용도 :

C형강 CHANNEL에  
결합하여 높낮이 조절 및  
흔들림 방지용으로 사용

표면처리 :

흑색도장(Black painting)



## 콤비 PAD 50W

\* CHANNEL 규격:60x30  
\* 허용하중:2000(kg/EA)

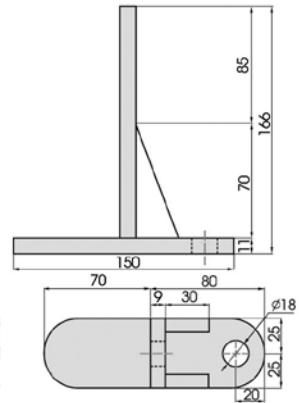
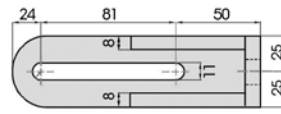

## 콤비 PAD 75W

\* CHANNEL 규격:75x45  
\* 허용하중:3000(kg/EA)

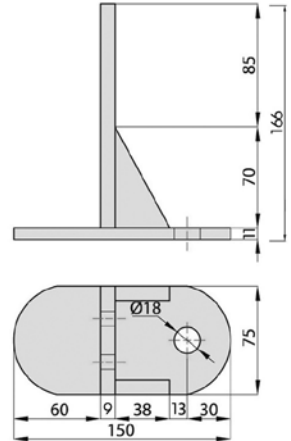
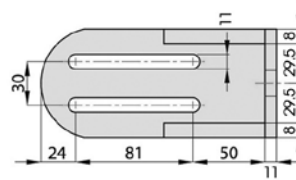

## 콤비 PAD 100W

\* CHANNEL 규격:100x50  
\* 허용하중:4000(kg/EA)

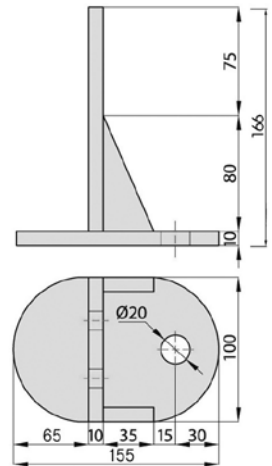
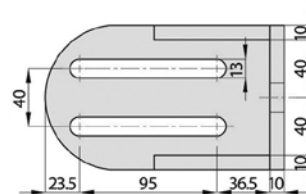

# 파렛트 컵

표면처리 : 무도금



MODEL	DIMENSIONS(m/m)			재질
	외경	내경	두께 및 높이	
사 각	120x120	60x60	3T 45H(라운드)	SPHC
	102x102	55x55	3T 40H	
	90x90	50x50	3T 40H	
원 형	125	70	3T 45H(라운드)	
	125	70	3T 47H(일반)	

# MFPU-98 & 하우스징

고하중용(HEAVY DUTY PURPOSE) / 장비용 LEVEL FOOT  
STEEL (흑색전기아연도금)

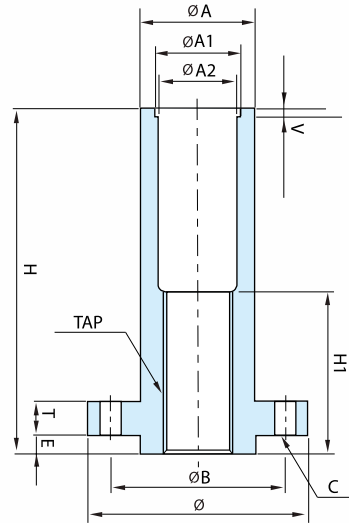
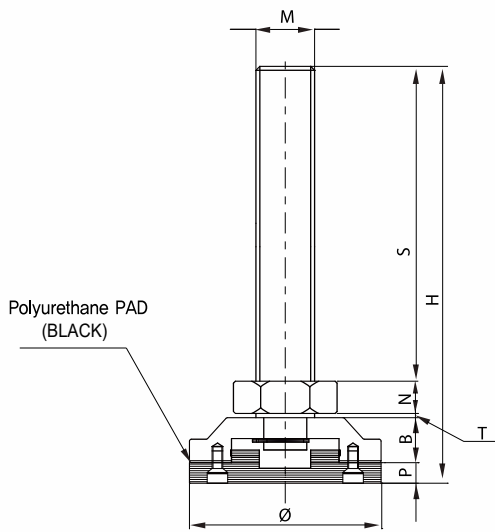

MODEL	DIMENSIONS(m/m)								MATERIALS		표면처리 (FINSH)	허용하중 (4EA/kg)
	Ø	M	S	H	N	T	B	P	BOLT&NUT	하부		
MFPU	98	M30x2.0 (가는나사)	150	196	17	1.5	23	4.5	SM45C	SM45C	흑색전기 아연도금	5000
			162	208								
			200	246								
			250	296								

## Housing

MODEL	DIMENSIONS(m/m)											
	TAP	Ø	ØA	ØA1	ØA2	ØB	H	H1	T	E	V	C
하우스징	M30x2.0	96	50	37.8	34	75	147	60	14	8	3	4-M8

### ■ 특징

가는나사 사용으로 정밀도를 요구하는 모든 장비에 적합

# WTr-Series

(30°사다리꼴 나사)

초고하중용(ULTRA HEAVY DUTY PURPOSE)  
STEEL (무전해니켈도금)  
(STAINLESS by order)

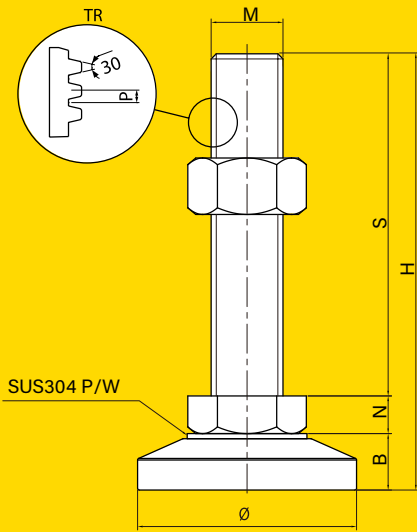

MODEL	DIMENSIONS(m/m)							MATERIALS		표면처리 (FINSH)	허용하중 (4EA/kg)
	Ø	M	S	H	N	B	P/W	BOLT&NUT	하부		
WTr42	128	M42x6	150	205	22	33					12000
			200	255							
			250	305							
			300	355							
WTr52	148	M52x7	150	215	27	38	3	SM45C	SM45C	무전해 니켈도금 (E-Ni)	16000
			200	265							
			250	315							
			300	365							
WTr60	148	M60x7	150	215	27	38					20000
			200	265							
			250	315							
			300	365							

※ 기타 특수사양은 주문제작함(PARTICULAR CASE IS MADE-TO-ORDER)

■ 사다리꼴 조절좌의 특징

- 사다리꼴 나사에 무전해 니켈도금을 함으로써 내열성, 내마모성, 비오염성 및 밀착성이 우수하고, Hv400~500 정도로 표면경도가 우수함. 열처리시에는 Hv900~1000까지 가능함.

Good for Heat resistance, Abrasion resistance and antipollution. The surface hardness normally Hv400 to 500, after heated Hv 900 to 1000 possible

■ 용도 : 반도체장비 LCD장비 자동화설비 전용기등

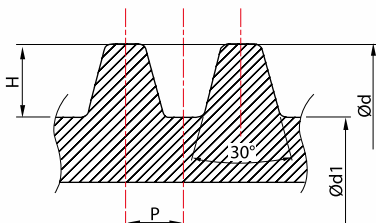

	P	d1	d	H
Tr42x6p	6	34.5	42	3.75
Tr52x7p	7	43.3	52	4.35
Tr60x7p	7	51.3	60	4.35

※Note

1. d1 : 골지름
2. d : 외경
3. H : 산높이



초고하중 베어링용  
(ULTRA HEAVY DUTY BEARING TYPE)  
STEEL (무전해니켈도금)  
(STAINLESS by order)

# WTrB-Series

(30°사다리꼴 나사)



※ 베어링 삽입으로 고하중시 높이  
조정이 용이

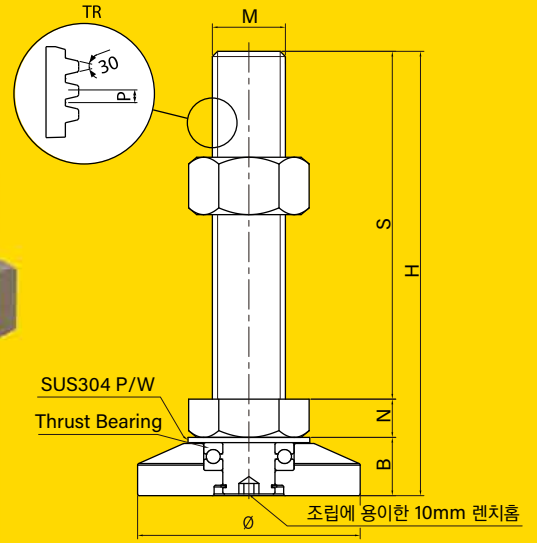

MODEL	DIMENSIONS(m/m)						MATERIALS		표면처리 (FINSH)	허용하중 (4EA/kg)	
	Ø	M	S	H	N	B	P/W	BOLT&NUT			하부
WTrB42	128	M42x6	150	205.5	22	33.5					12000
			200	255.5							
			250	305.5							
			300	355.5							
WTrB52	148	M52x7	150	215.5	27	38.5	3	SM45C	SM45C	무전해 니켈도금 (E-Ni)	16000
			200	265.5							
			250	315.5							
			300	365.5							
WTrB60	148	M60x7	150	215.5	27	38.5					20000
			200	265.5							
			250	315.5							
			300	365.5							

※ 기타 특수사양은 주문제작함(PARTICULAR CASE IS MADE-TO-ORDER)

### ■ 사다리꼴 조절좌의 특징

• 사다리꼴 나사에 무전해 니켈도금을 함으로써 내열성, 내마모성, 비오염성 및 밀착성이 우수하고, Hv400~500 정도로 표면경도가 우수함. 열처리시에는 Hv900~1000까지 가능함.

Good for Heat resistance, Abrasion resistance and antipollution. The surface hardness normally Hv400 to 500, after heated Hv 900 to 1000 possible

■ 용도 : 반도체장비 LCD장비 자동화설비 전용기등

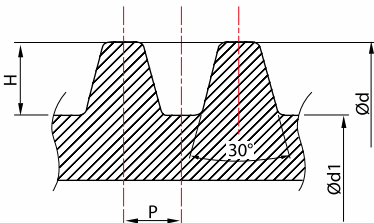

	P	d1	d	H
Tr42x6p	6	34.5	42	3.75
Tr52x7p	7	43.3	52	4.35
Tr60x7p	7	51.3	60	4.35

※Note

1. d1 : 골지름
2. d : 외경
3. H : 산높이

# WTr-Housing Series

## Bushing + Housing



WTH-FI



WTH-FP



WTH-W

### FI - TYPE(삽입형)

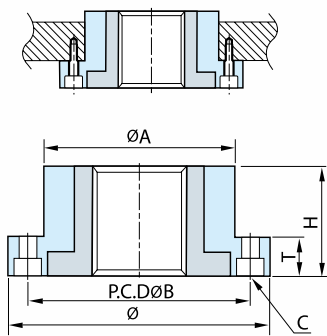

### FP - TYPE(돌출형)

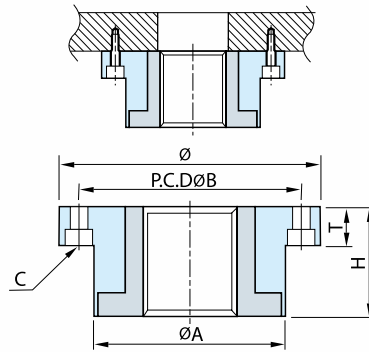

### W- TYPE(용접형)

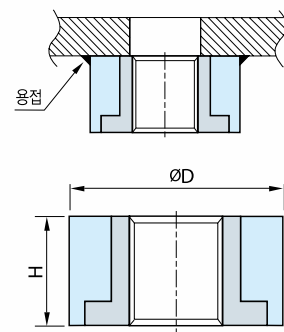

MODEL	DIMENSIONS(m/m)							
	규격	Ø	ØA	ØB	T	C	H	ØD
WTH-42	Tr42x6P	Ø147	Ø102	Ø122	25	4-M10 C'Bore	50	Ø117
WTH-52	Tr52x7P	Ø157	Ø112	Ø132	25	4-M10 C'Bore	60	Ø127
WTH-60	Tr60x7P	Ø167	Ø122	Ø142	25	6-M10 C'Bore	70	Ø137

#### 특징

- 내마모성 내소착성이 우수함
- 마찰계수가 작아 적은 토크로도 높낮이 조절이 용이함
- 상대물에 맞춰서 가공함으로써 정밀한 가공이 가능함

■ 용도 : 반도체장비 LCD장비 자동화설비 전용기등

#### Bushing Housing

- 재질 : SM45C (Sus304 by order)
- 도금 : 백색아연도금, 무전해니켈도금

## Bushing



TH



TH

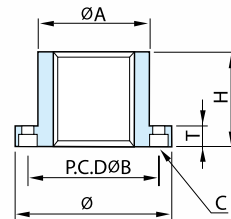

MODEL	DIMENSIONS(m/m)						
	규격	Ø	ØA	ØB	T	C	H
TH-42B	Tr42x6P	Ø97	Ø63	Ø78	15	4-M8 C'Bore	50
TH-52B	Tr52x7P	Ø107	Ø73	Ø88	15	4-M8 C'Bore	60
TH-62B	Tr60x7P	Ø117	Ø83	Ø98	15	4-M8 C'Bore	70

#### 특징

- 나사부 마모 및 파손시 BUSHING만 교체 후 사용가능함

#### Bushing

- 재질 : 황동(BS)

※ 기타 특수사양은 주문제작함(PARTICULAR CASE IS MADE-TO-ORDER)

# WSH-Series

WSH



WSH-160



WSH-200

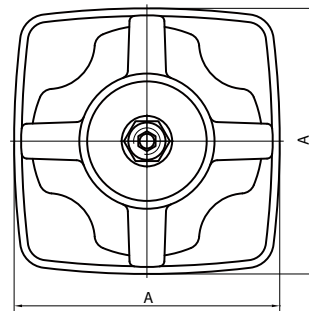
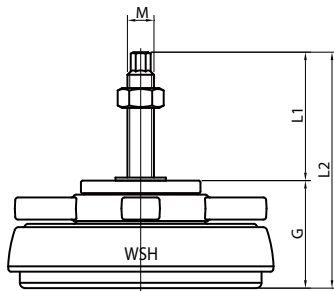

특징

- 1. 높낮이 조절기능
- 2. 경사면 자동보정

MODEL	L1	L2	조절 가능 높이	G	A	M	허용하중 (LOAD)
WSH-110	69	120	15	51	100	M12x1.75P	140 ~ 280Kg
WSH-130	83	138	20	55	130	M16x2.0P	280 ~ 600Kg
WSH-160	85	151	24	66	160	M16x2.0P	600 ~ 1,200Kg
						M20x2.5P	
WSH-200	100	182.5	27	82.5	200	M20x2.5P	1,200 ~ 1,800Kg
	190	272.5					

재 질(Material)

번호 NO	품명 PARTS	재 질 MATERIAL	표면처리 TREATMENTS
1	PAD	N.B,R (BLACK)	COLOR : BLACK 검정색
2	BASE	S45C	분체도장 (POUDER COATED)
3	HANDLE	S45C	분체도장 (POUDER COATED)
4	TILTING WASHER	S45C	아연도금
5	FLAT WASHER	S45C	아연도금
6	NUT	SS400	아연도금
7	BOLT	SS400	아연도금

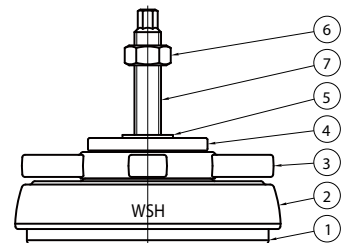

# OLP-Series

## ● Olp 'P' Type

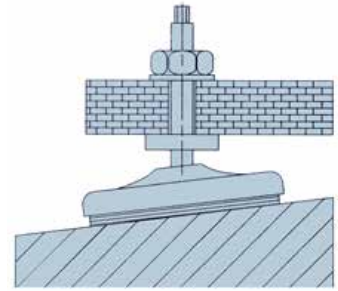
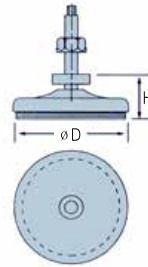

### Olp 'P' Type 규격

(unit:mm)

- 각종 산업용 기계에 가장 많이 적용되는 Type이며, 설치와 Level 맞추기가 쉽고 Pad에 따라 다양한 기계에 적용되며, 기계중량에 따라 Bolt Ø 크기가 선정된다.
- 적용기계 : 각종 Press, 사출기, 절단기, 절곡기, 제작기계 등

**M** 재 질 : FCD45

**H** 표면처리 : 도장(BLUE)

MODEL	ø D	H			허용하중(kg)			BOLT(M)
		15 PAD	20 PAD	25 PAD	15 PAD	20 PAD	25 PAD	
OLP-80	92	53	-	-	350	-	-	M16-100
OLP-100	112	-	64	69	-	600	800	M16-120
OLP-150	163	-	64	69	-	1,200	1,800	M16-150
OLP-200	225	-	81	86	-	2,000	2,800	M20-150
OLP-250	272	-	86	91	-	3,200	4,800	M24-150
OLP-300	330	-	-	93	-	5,000	6,500	M30-200

## ● Olp 'G' Type

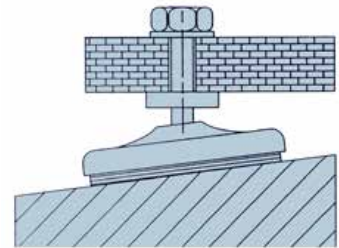
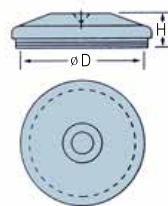

### Olp 'G' Type 규격

(unit:mm)

- 공작기계에 자체 Bolt를 이용하여 설치하는 방법과 Disk Bolt를 사용하여 설치하는 방법이 있다.

- 적용기계 : 밀링, 선반, 연삭기, 각종 공작기계 등

**M** 재 질 : FCD45

**H** 표면처리 : 도장(BLUE)

MODEL	ø D	H			허용하중(kg)		
		15 PAD	20 PAD	25 PAD	15 PAD	20 PAD	25 PAD
OLPG-80	92	32	-	-	350	-	-
OLPG-100	112	-	43	48	-	600	800
OLPG-150	163	-	43	48	-	1,200	1,800
OLPG-200	225	-	60	65	-	2,000	2,800
OLPG-250	272	-	65	70	-	3,200	4,800
OLPG-300	330	-	67	72	-	5,000	6,500

# 하중 분산판

● WILF-100A

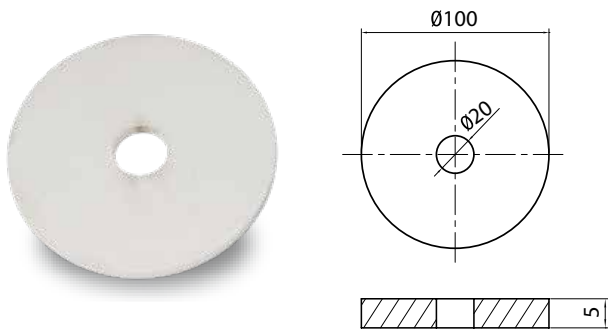

● WILF-100B

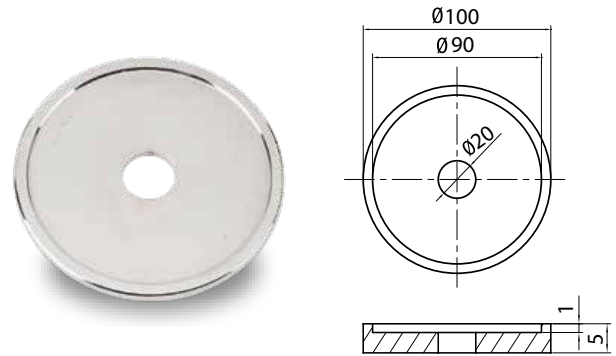

● WILF-100C

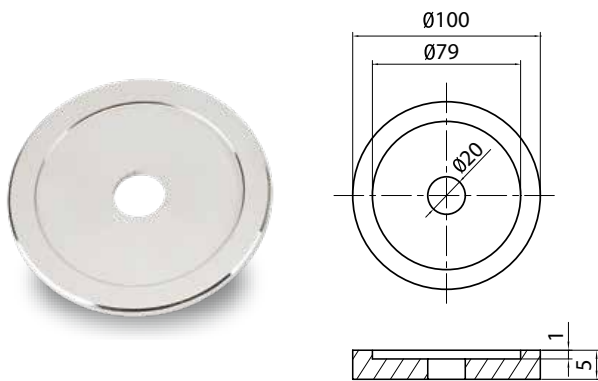

● WILF-110D

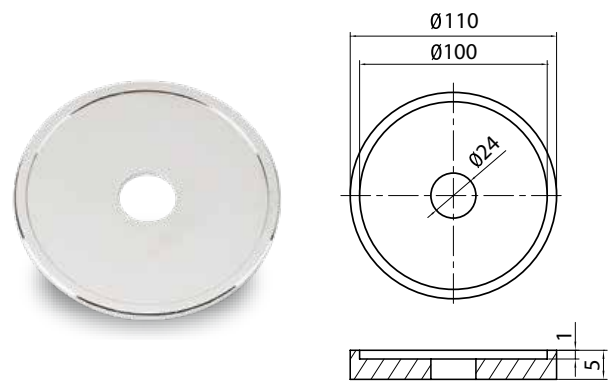

## Technical Data

WILF-100A, 100B, 100C, 110D	
Material	SS41
Surface Processing	ZN(백색), Ni(니켈)
Application	하중분산 받침대, 기타 내경SIZE 주문가능

\*주문 제작 가능



**CASTERS**  
**(WHEEL MASTER&WHEELS)**  
**LEVEL FOOT**  
**ACCESSORIES**  
**(PROFILE)**

[www.wooilcaster.co.kr](http://www.wooilcaster.co.kr)



본사 및 공장 : 경기도 안양시 만안구 덕천로72번길 27  
2 공 장 : 경기도 화성시 팔탄면 버들로1362번길 53-55  
Tel 031. 468. 7312 Fax 031. 468. 7334  
E-mail : webmaster@wooilcaster.co.kr  
[www.wooilcaster.co.kr](http://www.wooilcaster.co.kr)